

30 CVEREL

THE WORLD IN A CLICK

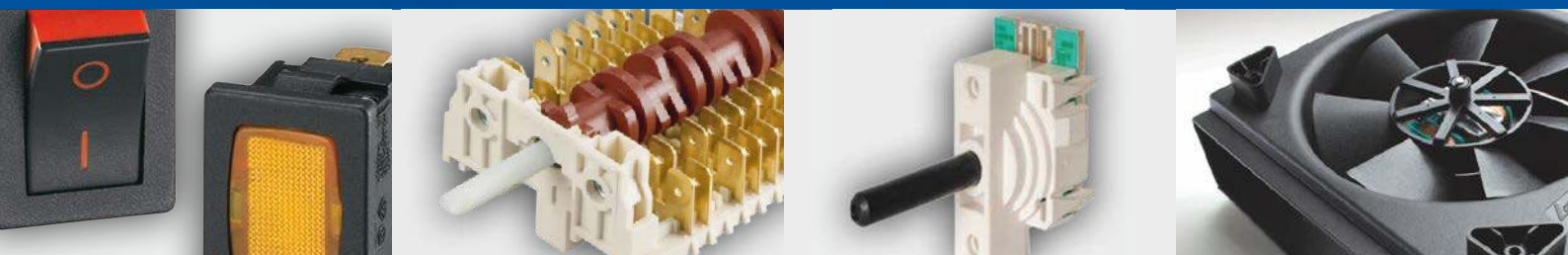

MINICODI



Dreefs

SIGNAL LUX

givem

MOLVENO

KAUTT & BUX

Minicodi

04



MS

199



MF

200



MB

200



MV

201



MK

202

MINICODI



TYPICAL APPLICATIONS	Electronic control for appliances
WIRING DIAGRAMAS	<ul style="list-style-type: none"> ■ 2-bit digital output (incremental function) ■ Up to 21 positions
CYCLE NR	10.000
AMBIENT TEMPERATURE	85 °C

Encoders display different dimensions and mounting systems on the control panel. Dimensions vary a lot depending on the different applications. MINICODI series as potentiometer can be coupled with selector switches.

ADDITIONAL FEATURES

- Golden contacts
- 360° with or without end stop
- Different mounting solutions available:
snap-in or M4 screws or self tapping screws
- Push to select version available
- Coupling with function selector switches
- Miniature encoder
- 2-bit digital output (incremental function)
- Typical use for analogical / resistive applications
- Permitted angular tolerance: +/- 2°
- End stops: ≥ 100 Ncm
- Operating torque: custom
- Edge connectors

Rating
20 mA / 5 VDC
T 85 °C

MINICODI - INCREMENTAL ENCODER

The mechanical encoder with digital output are available in absolute or incremental code. The shaft rotation, in the incremental output, generates pulses that, sent to the microprocessor, determine a “relative” position. The counts of pulses continue with the rotation of the shaft, which allows the position to change infinitely, or as the microprocessor allow. Direction may be determined by analyzing difference between the two channels.

Example of incremental encoder configuration with gray code

Detent	Ang.	Output	
		C	1 2
1	0°	■	■
2	30°	■	■ ■
3	60°	■	■
4	90°	■	
5	120°	■	■
6	150°	■	■ ■
7	180°	■	■
8	210°	■	
9	240°	■	■
10	270°	■	■ ■
11	300°	■	■
12	330°	■	

Example of incremental encoder obtained with momentary positions

Pos.	Ang.	Output	
		1	2
1 momentary	+30°	■	
0 stable	0		
2 momentary	-30°		■

MINICODI - POTENTIOMETER

The potentiometer is a mechanical encoder with resistive analogical output. The potentiometer version can be implemented either using a continuous “carbon” layer or a resistor array. The potentiometer has a rotation that can be infinite or steps (positions). Push to select function available.

Potentiometer resistor array

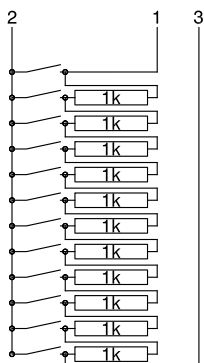

Pos.	Ang.	2	
		1	3
1	0°	10K	11K
2	30°	1	10K
3	60°	2K	9K
4	90°	3K	8K
5	120°	4K	7K
6	150°	5K	6K
7	180°	6K	5K
8	210°	7K	4K
9	240°	8K	3K
10	270°	9K	2K
11	300°	10K	1K
12	330°	11K	10

Potentiometer carbon film

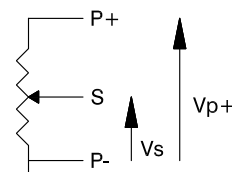

Value between P- and S		
Detent	Ang.	Output voltage %
1	0°	0%
2	35°	11%
3	70°	22%
4	105°	33%
5	140°	44%
6	175°	56%
7	210°	67%
8	245°	78%
9	280°	89%
10	315°	100%

endstop

MS

MINICODI	FIXING TYPE	H SHAFT (mm)	NUMBER OF POSITIONS
MS1	Screw m4	<ul style="list-style-type: none"> ■ 11 ■ 13 	<ul style="list-style-type: none"> ■ Free rotation 360° ■ Free rotation with mechanical stop
MS2	Self tapping screw	<ul style="list-style-type: none"> ■ 16 ■ 18 ■ 20,4 ■ 23 	<ul style="list-style-type: none"> ■ Positions number: min. 2 - max 21 with or without mechanical stop ■ Double momentary

MS1



MS1

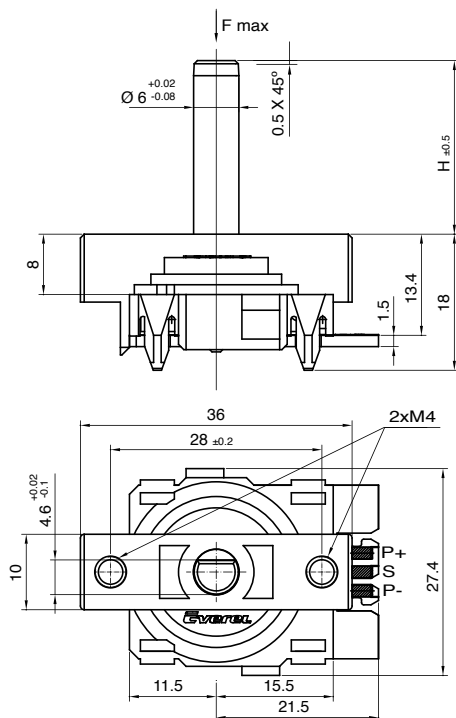

MS1 encoder, body standard version with M4 screw fixing type.

MS2

MS2

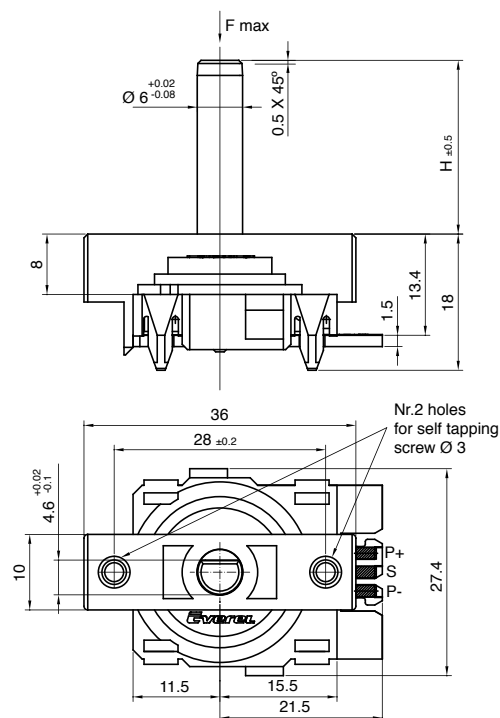

MS2 encoder, body standard version with self tapping screw fixing type.

MF



MINICODI	FIXING TYPE	H SHAFT (mm)	NUMBER OF POSITIONS
MF	<ul style="list-style-type: none"> ■ Self tapping screw ■ Snap in 	<ul style="list-style-type: none"> ■ 23 	<ul style="list-style-type: none"> ■ 3 P ■ 6 P ■ 8 P ■ 10 P ■ 12 P

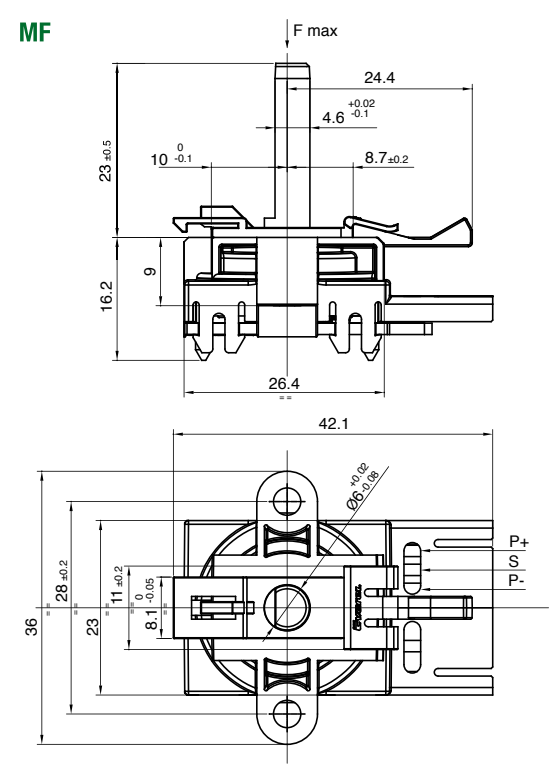

MF encoder, version with snap in fixing type or self tapping fixing type.

MB

MINICODI	FIXING TYPE	H SHAFT (mm)	NUMBER OF POSITIONS
MB1	Screw m4	<ul style="list-style-type: none"> ■ 13,7 cross ■ 23 	<ul style="list-style-type: none"> ■ Free rotation with 1 position at 0° ■ Free rotation with 20 positions
MB2	Snap in		

MB1

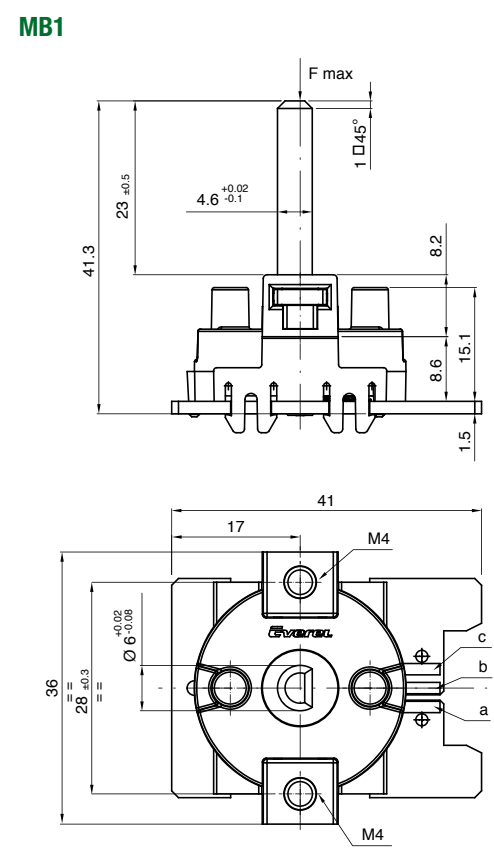

MB1 encoder, version with M4 screw fixing type.

MB2

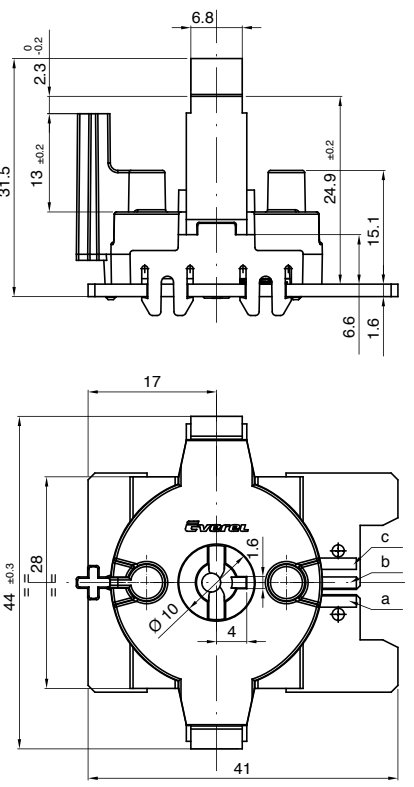

MB2 encoder, version with snap in fixing type.

MB2

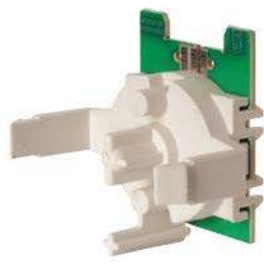

MV

MINICODI	FIXING TYPE	H SHAFT (mm)	NUMBER OF POSITIONS
MV1	Threaded ring	■ 12,7	■ Free rotation 360° with stop
MV2	Soldering pin		

MV1

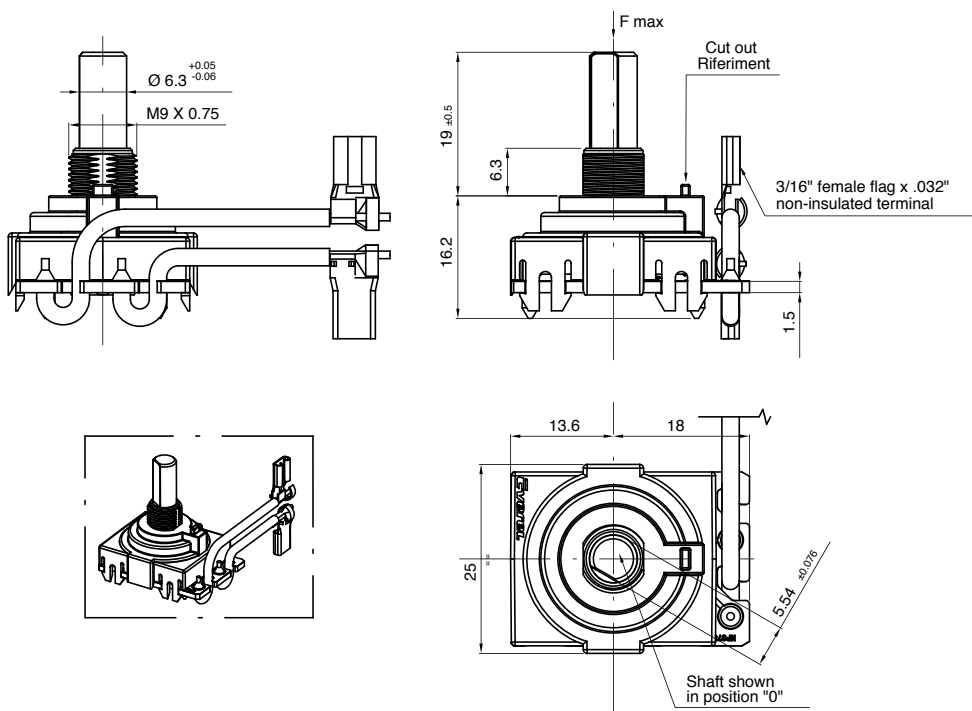

MV2

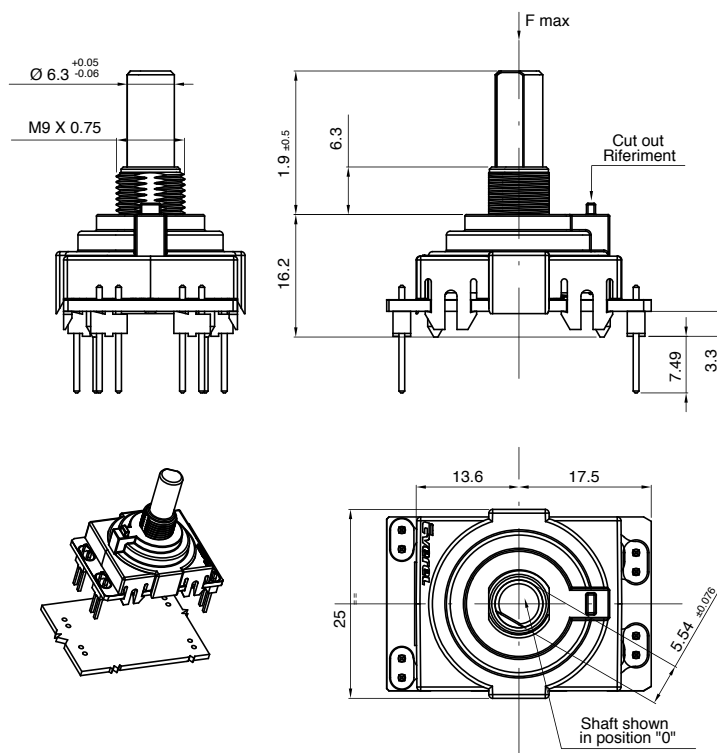



MINICODI	FIXING TYPE	H SHAFT (mm)	NUMBER OF POSITIONS
MK1	Screw m4	<ul style="list-style-type: none"> ■ 13 ■ 18,7 	<ul style="list-style-type: none"> ■ 21 positions free rotation ■ 20 positions free rotation
MK2	Self tapping screw	<ul style="list-style-type: none"> ■ 23 ■ 24 	<ul style="list-style-type: none"> ■ Double momentary

SHAFT

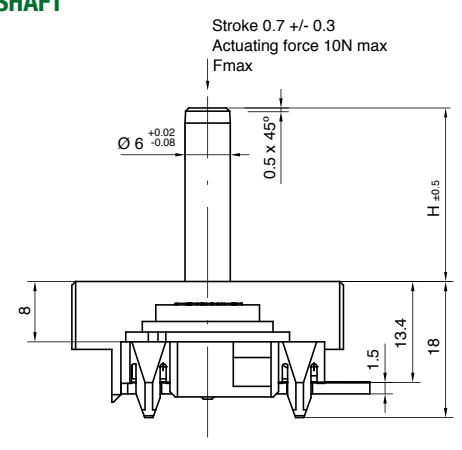

PUSH TO SELECT

The push to select accessory is used to select a scroll menu function and to confirm the selected value (i.e. temperature).

MK1



MK1

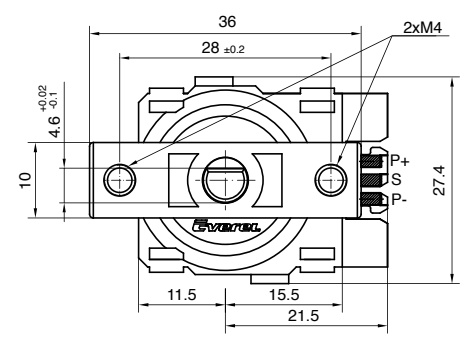

MK1 encoder, version with M4 screw fixing type.

MK2

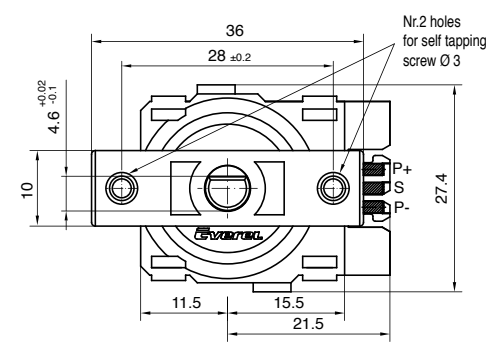

MK2 encoder, version with self tapping screw fixing type.

MK2



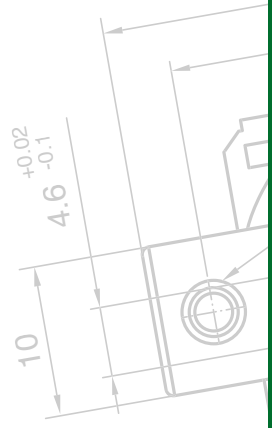
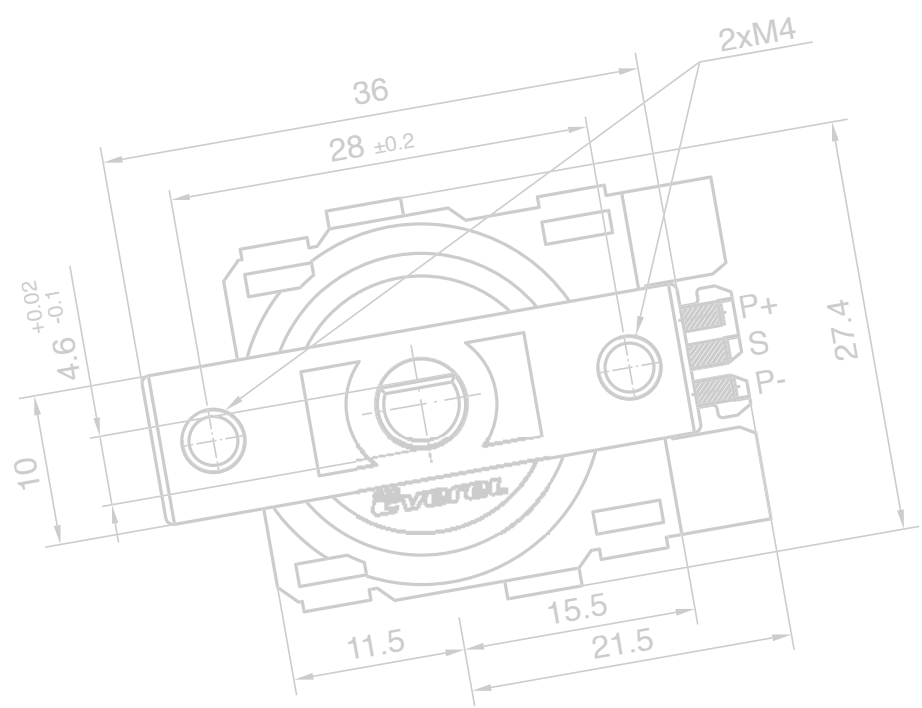
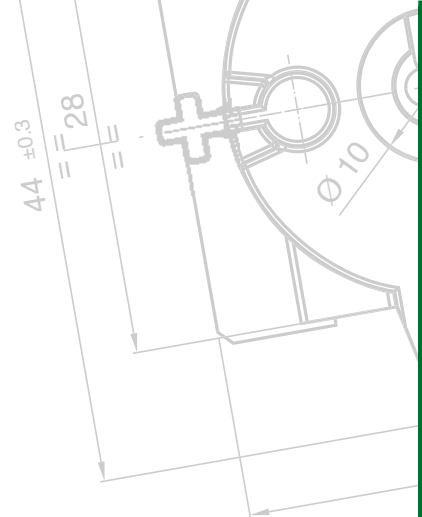
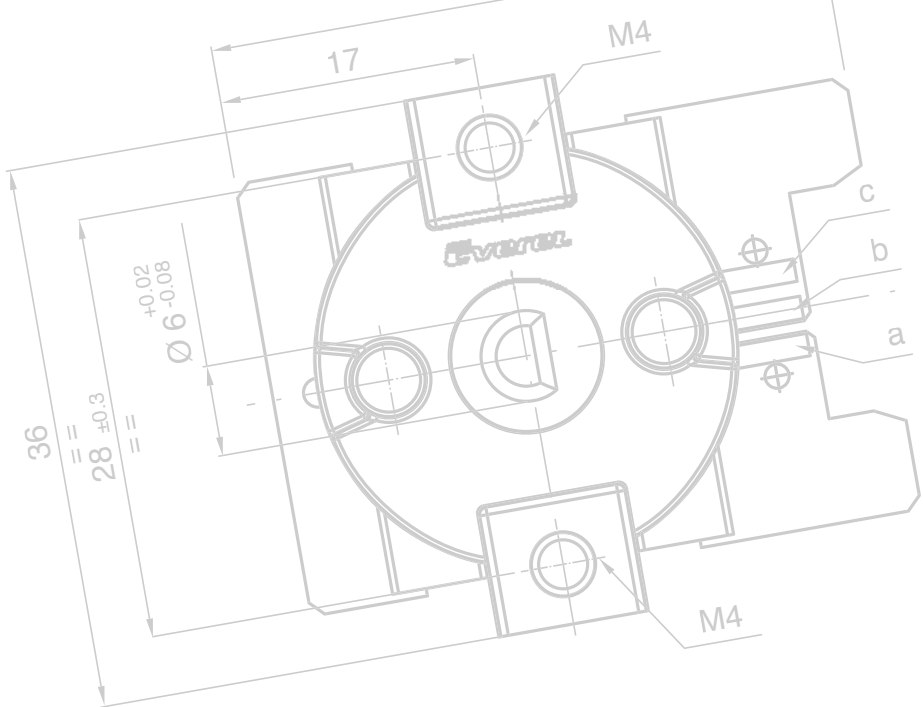

F max

Cut out Riferiment

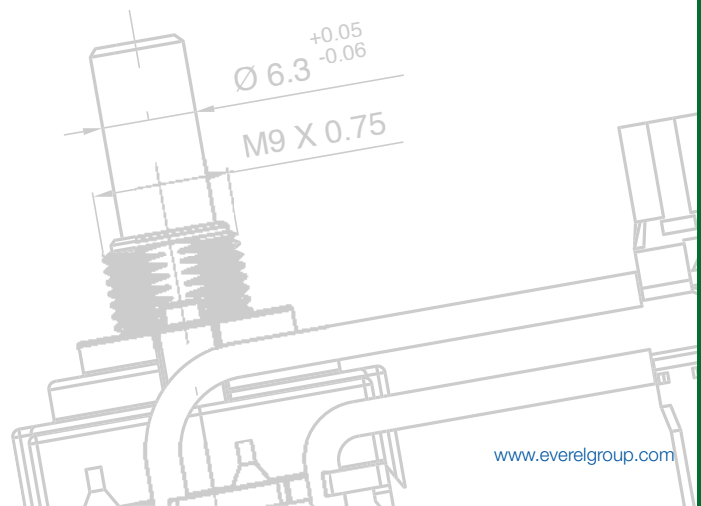



- Headquarter
- Production Site
- Sales Network



Everel Group S.P.A.

[Headquarter - Production Site]

Via Cavour, 9

37067 Valeggio sul Mincio (VR) - Italy

tel. +39 045 6313711

fax +39 045 6313730

Dreefs GmbH

[Production Site]

Ernst-Dreefs-Straße 7

96364 Marktrodach - Germany

tel. +49 9261 9610

fax +49 9261 961248

Everel Romania S.r.l.

[Production Site]

Calea Timisorii 109

Lipova - Arad - Romania

tel. +40 257 563087

fax +40 257 563086

www.everelgroup.com

